

# Device description

eVISIO PTE715



# Inhaltsverzeichnis

<b>1</b>	<b>General</b>	<b>6</b>
1.1	Preface	6
1.2	Liability	6
1.3	Security regulations and safty precautions	7
1.4	Copyright	7
1.5	Symbolics	8
1.6	Safety instructions	9
1.7	Before you start	11
1.8	Storage, transport and packaging	11
1.9	Warranty	11
1.10	Application area	12
1.10.1	Intended use	13
1.10.2	Structure of the visio terminal	13
1.10.3	Configuration	13
<b>2</b>	<b>Implementing</b>	<b>14</b>
2.1	Mechanical installation	14
2.1.1	Space requirement	14
2.1.2	Installation / Assembly	14
2.1.3	Assembly/Disassebly	14
2.1.4	Mounting position	15
2.1.5	Required space	16
2.1.6	Mounting	16
2.1.7	Disassembly	17
2.1.8	Dimension drawing	18
2.1.9	Dimensional drawings mounting cutout	18
2.1.10	Dimensions	18
2.2	Elektrical Installation	19
2.2.1	Supply voltage	19
2.2.2	EMC-compliant design	19
2.2.3	Connection to other elrest master -devices	20
2.2.4	EGB / ESD- guidelines	21
2.2.5	Guidelines	22

2.2.6	Label.....	23
<b>3</b>	<b>System overview.....</b>	<b>24</b>
3.1	Communication interfaces .....	24
<b>4</b>	<b>Device descriptions.....</b>	<b>25</b>
4.1	Technical data .....	25
4.1.1	Dependence of the storage temperature to the humidity.....	27
4.2	Rear view of the interfaces .....	28
4.3	Terminal assignment.....	29
4.3.1	X1 : Power supply .....	29
4.3.2	Function earth (FE) .....	29
4.3.3	X2 Gigabit Ethernet interface.....	30
4.3.4	LEDs for the Ethernet interface .....	31
4.3.5	X4 USB0 2.0 Host interface.....	31
4.3.6	S2 key „SLEEP / RESET“.....	31
4.3.7	S3 key „INT“ .....	32
4.3.8	Battery compartment.....	32
<b>5</b>	<b>Software.....</b>	<b>33</b>
5.1	General informationen.....	33
5.1.2	RTC (Real time clock).....	33
5.1.3	Turn on.....	34
5.1.4	Login.....	35
5.1.5	Desktop.....	36
<b>6</b>	<b>Maintenance and servicing .....</b>	<b>37</b>
6.1	Maintenance.....	37
6.1.1	General.....	37
6.1.2	Changing backup battery .....	37
6.1.3	Device temperature.....	38
6.1.4	Cleaning .....	39
6.1.5	Device failure .....	39
6.1.6	Accessory.....	39
<b>7</b>	<b>Troubleshooting .....</b>	<b>40</b>
7.1	Service and Support.....	40
<b>8</b>	<b>List of figures.....</b>	<b>41</b>
<b>9</b>	<b>List of tables.....</b>	<b>41</b>

Preliminary

# Imprint

©2017 by elrest Automationssysteme GmbH  
All rights reserved

## **elrest Automationssysteme GmbH**

Leibnizstraße 10  
732320 Kirchheim unter Teck  
Germany

Phone: + 49 (0) 7021 / 92025-0  
Fax: + 49 (0) 7021 / 92025-29

e-mail: [vertrieb@elrest.de](mailto:vertrieb@elrest.de)  
Web: <http://www.elrest.de>

## **Technical Support**

Phone: +49 (0) 7021 / 92025-33  
Fax: +49 (0) 7021 / 92025-29  
e-mail: [support@elrest.de](mailto:support@elrest.de)

This document was carefully created, in order to ensure the correctness and completeness of the documentation.

Since, in spite of all the care taken, errors can never be completely avoided, we are always grateful for advice and suggestions.

# 1 General

## 1.1 Preface

This manual contains texts, illustrations and explanations for the correct installation and operation. This manual must be read and considered before installation and employment of the devices.

This documentation is mainly directed towards qualified personnel to control and automation technology. They must be well acquainted with the current standards and guidelines.

If you have any questions about the installation, application and operation, please contact the *elrest* customer hotline:

Phone: 07021/92025-33

Fax: 07021/92025-59

E-Mail: [hotline@elrest.de](mailto:hotline@elrest.de)

or contact your responsible agency.

This manual is published subject to any changes. Changes can be made without reference.

## 1.2 Liability

The documentation was carefully compiled.

All examples and illustrations in this manual serve only as assistance for understanding the text. Changes without references can be made. We do not assume any liability for the correctness of the represented operations. No claims for the modification of products that have already been supplied may be made on the base of the texts, explanations and illustrations in this documentation. *elrest* Automationsysteme GmbH takes on no responsibility for an application of products, which refers to the represented examples (e.g. in eStudio demo).

*elrest* Automationsysteme GmbH assumes under no circumstances the liability or responsibility for damage, which resulted from an inappropriate installation, respectively an application of the devices or the accessories.

The staff must ensure that the installation and the application of the products according all of the safety requirements, laws, regulations and standards

In each case the national regulations and the valid safety regulations have to be considered.

Interferences and changes in the devices automatically render the warranty void.

### 1.3 Security regulations and safety precautions

This manual was provided for trained and competent personnel. The qualification is defined by the European guidelines for machines, low-voltages and EMV. The connection and the assembly of the devices can be carried out only via an electrical specialist, if the voltages are higher than the Safety Extra Low Voltage (SELV).

In each case the national regulations and the valid safety regulations have to be considered. Interferences and changes in the devices automatically render the warranty void.

Due to the large number of different applications for these devices, you must adapt yourself for your particular application.

If circuit components should fail, appropriate safety devices must ensure that the attached periphery is stopped.

Do not try to repair the devices themselves or exchange electrical parts. Please turn exclusively to the elrest service department. You can contact us on the elrest-hotline.

Consider the local, national standards and regulations during the installation and the employment of the devices.

The relevant regulations (VDE etc.) while handling electrical system are to be considered:

- To activate
- Prevent unintentional restart
- The unit must be deenergized
- Ground and short-circuiting
- No ground-loops.
- Cover or shield nearby live electric parts.

### 1.4 Copyright

Copyright © 2017 elrest Automationssysteme GmbH (in further consequence "elrest" mentioned) all rights are reserved.

All parts of the software and the documentation are subject to copyright. The software described in this manual must be used exclusively in the context of the license terms.

No part of the documentation and software may be reproduced or assimilated by use an electronic data processing system, reproduced or spreaded in any form without a written permission of the company elrest (pressure, photocopy, microfilm or another procedure). The expressly exceptional cases, named in the paragraphs 53 und 54 UrhG, are not affected.

All measures have been taken to ensure the correctness and completeness of the information in this documentation. Nevertheless, errors cannot be excluded. The company elrest cannot assume legal responsibility or any liability for damage, which results from the use of information from this manual or from the use of the program described in this documentation.









The product names mentioned in this manual are trade marks or registered trade marks of the respective

manufacturing firms and are hereby accepted.

The information, contained in this document, may be changed without advance NOTICE and represents no obligation on the part of elrest.

## 1.5 Symbolics

In this manual different symbols are used for the emphasis of certain information. Hereby the service personnel receive necessary references to the safety and preventive measures. With each occurrence of the symbols the associated reference has to be read.

<p>DANGER</p> 	<p>Indicates a directly threatening danger situation which may result in damage to persons or property.</p>
<p>WARNING</p> 	<p>Indicates a possibly arising danger, which may result in damage to persons or property.</p>
	<p>Indicates notes, thereby the handling gets easier.</p>
<p>DANGER</p> 	<p>Personal injury caused by electric current! Indicates a high-risk, imminently hazardous situation which, if not avoided, will result in death or serious injury.</p>
<p>DANGER</p> 	<p>Personal injury caused by electric current! Indicates a high-risk, imminently hazardous situation which, if not avoided, will result in death or serious injury.</p>
<p>WARNING</p> 	<p>Warning of damage to persons Indicate a possible danger with moderate risk that can result in death or (severe) bodily injury if it is not avoided.</p>
<p>CAUTION</p> 	<p>Warning of damage to persons Indicates a low-risk, potentially hazardous situation which, if not avoided, could result in slight to moderate injury.</p>
<p>CAUTION</p> 	<p>Warning of damage to material Indicates a possible danger which can result in material damage, when it cannot be avoided.</p>











ESD 	Damage to Property Caused by Electrostatic Discharge (ESD)! Indicates a potentially hazardous situation which, if not avoided, may result in damage to property
NOTICE 	Important Note! Indicates a potential malfunction which, if not avoided, however, will not result in damage to property.
INFORMATION 	Further information Refers to further information, which is not a substantial component of this documentation (e.g. Internet)
 ST	(* comment to CoDeSys code lines *)  a := a+1;

Table 1:Symbolics

## 1.6 Safety instructions

For installing and operating purposes of the relevant device to your system the following safety precautions shall be observed:

DANGER 	Don't assembly the devices under voltage! Always switch off the power supply before assembling the device, eradicating defaults or carrying out maintenance operations.
DANGER 	Take note of the general regulations on prevention of accidents! Take note of the relevant regulations on prevention of accidents, e.g. the regulations during installation and commissioning of BGV A 3 "electrical installations and equipment" for mounting, installation and eradicating defaults.
DANGER 	Take note of connection in compliance with the standard! To avoid risks of the staff and the disturbances on the device, install the data- and the supply line conforming to standards. Take note of the correct assignment of connections. Observe the relevant EMC directives for your application.
ATTENTION 	Replace defective or damaged device! Replace defective or damaged device/module (e.g., in the event of deformed contacts), since the long-term functionality of fieldbus station involved can no longer be ensured.

<p>ATTENTION</p> 	<p>Shield the devices from creeping and isolating materials!</p> <p>The components are not resistant against materials which have creeping and insulating properties such as: aerosols, silicones and triglycerides (found in some hand creams). If it cannot be excluded that these substances are in the environment of the device, incorporate the device in a cage which is resistant against the above-named substances. Always use proper tools and materials for the maintenance.</p>
--	--

Table 2: Safty note

Preliminary

## 1.7 Before you start...

Before switching-on the supply voltage, please check definitely:

- The wiring
- Possible interference
- Free circulation around the heatsink

## 1.8 Storage, transport and packaging

The delivery has to be checked for completeness after the receipt. Possibly determined transport damages shall be notified to the shipping company and the manufacturer immediately. In the case of a possible temporary storage it is recommended to use the original packaging. The storage must be clean and dry. According the §BGB §446 and §448, the transfer of perils of the purchased product will pass to the buyer from invoicing. elrest does not assume any liability for the transport risk. If the carrier's liability of the transport enterprise does not cover the commodity value, it is incumbent on the buyer to conclude an additional transport insurance.

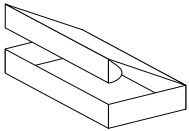

The devices are delivered in a suitable packing. To avoid damages please remove the packing before using the device. If the packing includes further accessories or descriptions, consider and keep them absolutely.

## 1.9 Warranty

A warranty claim presupposes a professional assembly and start-up, based on a valid assembly-, commissioning instruction and the operating instructions. The necessary assembly, start-up and maintenance work may be accomplished only by adept and authorized persons. See our EULA regulations too.

### Manufacturer

elrest  
Automationssysteme GmbH  
D-73230 Kirchheim unter Teck

Leibnizstraße 10

Phone: +49 (0) 7021/92025-0

Fax: +49 (0) 7021/92025-29

### Trademark



### Country of origins

Germany

## 1.10 Application area

These terminals are mostly suited for simple operations and observations.

The PTE is intended to be used for direct connection to controllers with their own Web servers. The terminals receive the display information from a combo (CMxxx) or robusto master (RMCxxx) and activate via touchscreen configured operating tasks. The operating project is stored centrally in the master.

The ETHERNET-based protocols and network variables support communication.

In addition, the terminals can also be operated on external products.

<p>Notice</p> 	<p>Never exposing the device in a direct bright light source, such as sunlight.</p> <p>A small number of defective pixels in the display can occur despite state-of-the-art production processes. This is not a function restriction.</p> <p>Burn-in (Screen Burn): Continuously displayed static images could lead that individual pixels become over used during extended periods.</p> <p>Silhouettes of preceding screen images will be remaining visible. The burn-in effect occurs.</p>
---	--

### 1.10.1 Intended use

The devices are intended for the use in the ranges of the regulation, control and automatic control engineering.

Within all ranges, particularly when using inductive loads (e.g. engines and relay etc.), it must be guaranteed that arising voltage peaks don't exceed the maximum input voltages of the entrances and exits. If necessary, external predicting circuit parts must be installed.

The devices are exclusively intended for the installation in machines and plants. Start-up is forbidden until the conformity of the final product with the guideline 2006/42/EG „machine guideline “is determined.

With certain devices, external measures (e.g. a special power supply) can be necessary, in order to achieve the required interference immunity against surge). In this case, it will be pointed out at the respective device.

It will be applied accordingly to the appropriate device, if external measures are necessary for the minimization of the radiated interference.

Further the environment can affect the radiated interference.

Fulfils a device the “higher” engineer standards (e.g. EN 61000-6-3:2007 generic standard emission: Living quarters, business and industrial areas and small enterprises), it will be applied accordingly to the appropriate device (see to chapter „data sheets “).

<p>WARNING</p> 	<p><b>Warning!</b></p> <p>This is a Class A product. In a domestic environment, it may cause radio interference, in which case the user may be required to take adequate measures.</p> <p>Designates a possibly arising danger, which can lead to a damage to property or person</p>
--	--

### 1.10.2 Structure of the visio terminal

- Metal housing, glass
- Front panel mounting
- Connections via plug connection

### 1.10.3 Configuration

Ethernet communication level is available.

The selected configuration of the hardware must be accorded to the setting of the peripheral components. Malfunctions may otherwise occur, if no safty prompts are programmed in the application.

	<p>Visio components can only be (dis-)connected to the system in the „power-off state“ of all system components.</p>
---	--

## 2 Implementing

### 2.1 Mechanical installation

Safety notes at the workplace:

Before installing and starting up, the manual must be read and followed carefully. The relevant EN and VDE regulations are valid.

<p>WARNING</p> 	<p>Before starting up, adapt the device to the room temperature. By condensation you can switch on the device only after it is completely dry.</p> <p>To prevent the device from overheating:</p> <ul style="list-style-type: none"><li>- avoid direct sun contact to the device,</li><li>- do not cover the vents,</li><li>- ensure sufficient air circulation</li></ul>
--	---

#### 2.1.1 Space requirement

There must be considered sufficient access to the equipment, for the operator and for maintenance work during the installation.

Ensure sufficient air circulation during installation.

#### 2.1.2 Installation / Assembly

The valid local, and in particular, electrical safety regulations must be kept.

Safety notes at the workplace:

- The devices are intended for installation in switching cabinets
- The protection rating IP20 has to be warranted;
- The installation point has to be in a solid position with low vibration.



#### 2.1.3 Assembly/Disassembly

As standard, the mounting position is vertical. (See chapter [Mounting position](#))

According to the installation positions, the valid maximum ambient temperature has to be respected.

<p>WARNING</p> 	<ul style="list-style-type: none"><li>• Ensure that there is sufficient clearance between the neighboring devices that the natural convection can ensure sufficient cooling.</li><li>• Bring the system into a safe, de-energized state before starting installation, disassembly or wiring of the device!</li></ul>
--	--

NOTICE 	<p><b>NOTICE the temperature range at a different mounting position!</b></p> <p>In the chapter <a href="#">Technical data</a> is the range of temperature specified. It is valid for the recommended ambient working temperature. If the device will be mounted in a different mounting position as recommended, the cooling will be affected. Please contact the elrest service for further information.</p>
---	---

	<p>Bring the system into a safe, de-energized state before starting installation, disassembly or wiring of the device!</p> <p>THE DEVICE MUST BE CONNECTED TO THE FUNCTIONS (FE).</p>
	<p>All communication interfaces of the device have additionally be connected to the function earth (FE) in the communication plug (if available).</p> <p>The cable screens of the communication interfaces must be connected by the mating connectors with the FE.</p>
	<p>The power supply (24 VDC) must be, in accordance with its requirements (e.g. amount of all 24 V driver outputs), adequately dimensioned and secured.</p>

### 2.1.4 Mounting position

The mounting position is available in

- Landscape, or
- Portrait

The applicable maximum ambient temperatures must be observed for the appropriate installation positions.



Device	Mounting position			
	horizontally	obliquely $\pm 45^\circ$		vertical
	 or 			
PTE715	0 °C ... 45 °C	0 °C ... 45 °C		0 °C ... 45 °C
Permissible storage temperature		-20 °C ... +70 °C		
Relative humidity for operation		10 % ... 85 %		
Operating height		0 m ... 2000 m		

Table 3: Mounting position

### 2.1.5 Required space

With assembly in a switch cupboard, please ensure sufficient access to the device for the operator and maintenance work.

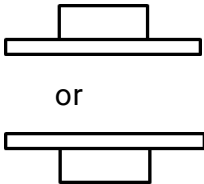
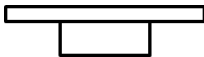
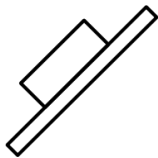
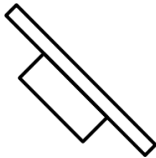
Ensure a minimum distance of 80 mm from the back and circumferentially 50 mm.

Care must be taken for sufficient air ventilation.

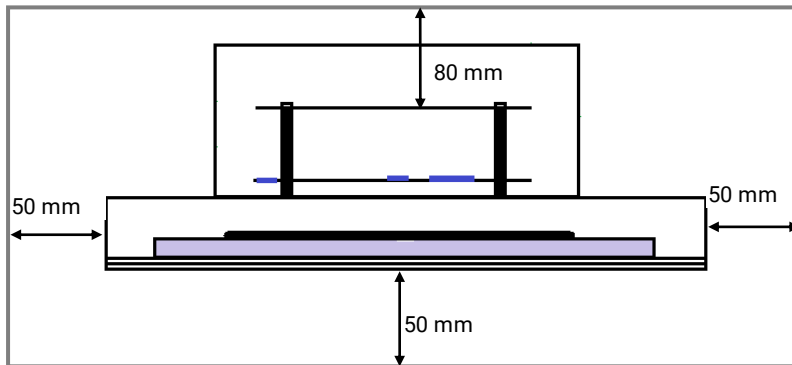

Figure 1: Required space

### 2.1.6 Mounting

For easy front mounting, springs are mounted in the housing.

With the springs can be placed the device in the cutout and subsequently fixed in the mounting opening with the clamping blocks

The spring clip mounting is not suitable for protection class IP54. Therefore, terminal blocks are required as an additional attachment for retrofitting and maintaining the IP54 requirement. (see chapter „[Dimension Drawing](#)“)

#### 2.1.6.1 Number of the terminal blocks

 <p>Figure 2: Symbolic illustration Terminal block for mounting</p>	<p>PTE715 aluminium:</p> <ul style="list-style-type: none"><li>10 terminal blocks</li><li>1 x MB225-3 set of terminal blocks (6 pieces)</li><li>1 x MB225-8 set of terminal blocks (4 pieces)</li></ul>
--	---



### 2.1.6.2 Position of the terminal blocks

The mounting plate for mounting the panel must not be more than 6 mm thick.

#### Torque:

The screw is tightened by hand for the correct torque.

That the seal is evenly fitting, the following value for the tightening torque has to be applied:

PTE715                      0,2 Nm

	<p>Tighten the screws just so that the seal between the front and the mounting cutout is completely compressed and sealed. Too strong and / or uneven tightening of the screws can damage the device!</p> <p>Only if all clamping bolts are used, the tightness IP54 (front) can be achieved.</p> <p>Overturning the screws can destroy the block.</p>
--	--

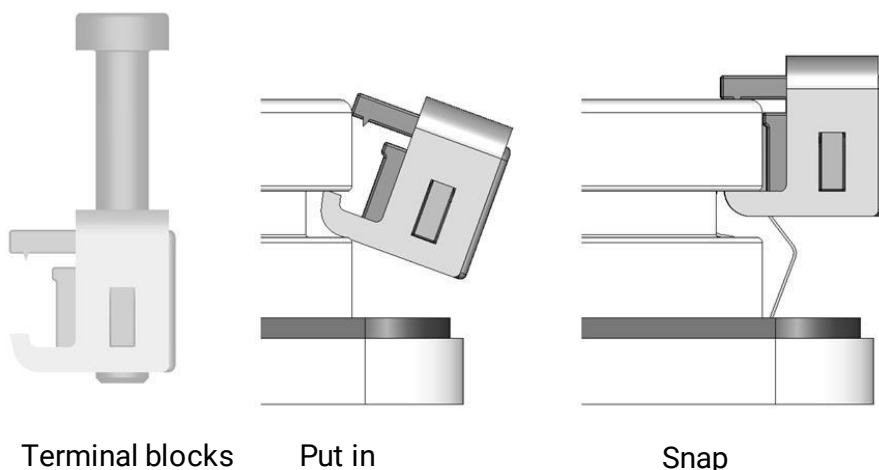

Figure 3 : Attaching of the brackets on the mounting plate

### 2.1.7 *Disassembly*

Loosen the fastening screw. Thread should complete with plastic body. The disassembly is carried out in the reverse order of assembly.

### 2.1.8 Dimension drawing

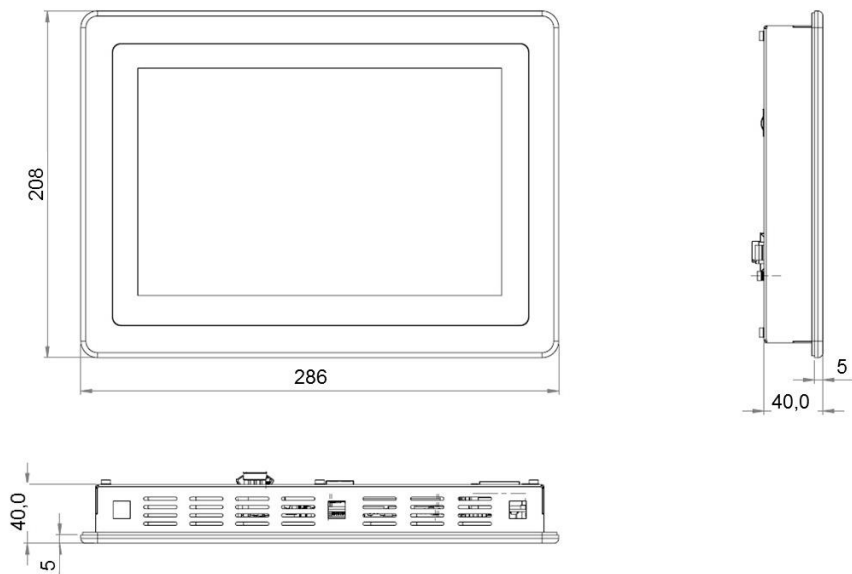

Figure 4: Dimension drawing PTE507

### 2.1.9 Dimensional drawings mounting cutout

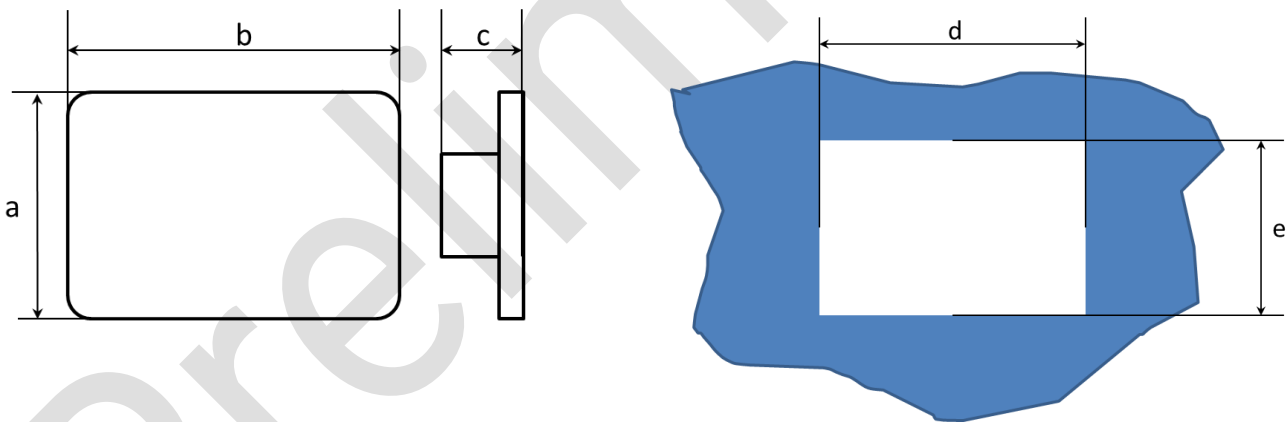

Figure 5: Dimension drawing and mounting cutout

### 2.1.10 Dimensions

Device	A Height [mm]	B Length [mm]	C Depth [mm]	D Length cutout [mm]	E Width cutout [mm]
PTE715	262	410	50	396	246

Table 4: Dimension of the device

## 2.2 Electrical Installation

### 2.2.1 Supply voltage

Proceed with start-up generally as follows:

- Attach the supply voltage for the device to X1
- Turn the power supply on

	<p>The supply voltage connection of the control component from the device has polarity protection.</p> <p>If several connection points are available for the identical potential, than no potential difference between them is allowed. Otherwise, the resulted compensation currents can lead to irreversible damages of the device. Therefore, provide a suitable equipotential bonding!</p> <p>For the 24 V – supplier ensure a reliable electrical isolation of the low voltage. Only use power supply units manufactured to the standards IEC 364 - 4 - 41 / HD 384.04.41 (VDE 0100 Part 410).</p> <p>Only use power supply units in accordance with SELV and PELV specifications!</p> <p>The supply voltage may be intermediate within the specified voltage range! Otherwise this may cause malfunction on the device. See the technical specifications for the supply voltage requirements.</p> <p>High frequency radiation, from mobile phones for example, can cause unintentional operating situations.</p>
---	--

#### 2.2.1.1 2.2.1.1 Connectors for power supply

For the connectors only use the specified manufacturer types, unequal connectors can damage the pin connectors.

All plug connectors have to be plugged correctly, otherwise a contact resistance occurs.

⇒ Press on the plugs on several places and hold for a few seconds until they lock.

	<p>Never disconnect plugs when under load. Faulty or incorrect connection may cause malfunction on the device</p>
---	---

### 2.2.2 EMC-compliant design

The basis for an interference-free operation is an EMC-compliant hardware construction of the system, as well as the use of interference-free cables. The guidelines for interference-free installation of your system are accordingly to the installation of the devices.





For all signal connections are allowed only protected lines.

- All plug connectors must be screwed or locked;
- Signal lines and high-voltage cables are not allowed to lead both in the same cable duct;
- For malfunctions and damages caused by the use of unsuitable cable, no liability can be accepted;
- Unused signals (e.g. unused interfaces, battery connections, etc.) have to be adequate covered to avoid electrostatic influences (ETUC/ESD);
- Cables only plug in/off when the device is turned off.
- During the operation, all connected cables must be connected to a remote peer.

### 2.2.3 Connection to other elrest master -devices

For the Ethernet-interface X2 can be used commercial RJ45-plugs (8- pol) of good quality. High quality CAT-V cables are recommended.

Establish the connection as follows:

Order number:	24BF1.D001	Accessories	23113.000x or 25150.0xxx
Designation	PTE715	Patch cable RJ-45 to RJ-45	Combo master CM2xx Robusto master RMC5xx
			

The individual accessory components can be taken from the chapter [Accessory](#).

Figure 6: Connection to other elrest master -devices

## 2.2.4 EGB / ESD- guidelines

### 2.2.4.1 What means EGB/ ESD

Nearly all modern modules are equipped with highly integrated chips or components in MOS technology. These electronic components are very sensitive to overvoltage and therefore to electrostatic discharge.

The international abbreviation for ESD means Electrostatic Sensitive Device.

This symbol is on cabinets, subtracks, or packing boxes and indicates the use of electrostatically sensitive devices and thereby sensitivity by touching the devices:



EGB /ESD sensitive components may be damaged by energies and voltages that are below the limit of human perception. This kind of voltages occurs when somebody, which is not electrostatically discharged, touches a module/chip/component. In most of the cases, the components exposed to such overvoltages can not immediately be detected as defective. Only after long operating of the device may an error occur.

An installation that conforms to EMC requirements as well as the use of interferencefree cables represents a basic requirement in ensuring trouble-free operation.

The directives for interference-free installation of your device also apply for the installation of the HMI device.

### 2.2.4.2 Protective measures against static charge

The most plastics are hard chargeable and therefore must be kept away from ESDs!

Ensure that operators, work area, and packaging have proper grounding when working with ESDs!

### 2.2.4.3 Handling of ESD-Modules

Basically, the electronic boards should be touched only when it's absolutely necessary. Never touch the chip connectors and live conductors of a flat electronic module.

Touch the electronic components **only**, if you are permanently grounded via the ESD wristband, ESD shoes, or shoes with protecting strip in constant touch with an ESD floor.

Discharge your body before touching any electronic module. For example, by touching electrically conductive and grounded material (e.g. grounded bare metal cabinet parts, water pipes...).

Electrostatic sensitive components or modules must not get in contact with materials which are chargeable including all standard types of plastic, desk top, and clothes with synthetical material and so on. Components must only be placed on conductive surfaces. (table with ESD- layer, ESD conductive cellular material, ESD packaging, ESD container)

Do not place the components near visual displays and monitors or television sets. (Keep a minimum distance of 10 cm)

### 2.2.5 Guidelines

The conformity of the above specified products with the provisions of the Directive 2004/108/EG, 2006/95/EG und 2011/65/EG is supported by the respect of the following standards:

#### 2.2.5.1 Product standard

EN 61000-6-2:2015

Electromagnetic compatibility (EMC) - Part 6-2: Grounding principles - Immunity for industrial areas (IEC 77/488 / CDV: 2015); English version FprEN 61000-6-2: 2015

EN 61000-6-4:2011

Electromagnetic compatibility (EMC) - Part 6-4: Generic standards - Emission standard for industrial environments (IEC 61000-6-4:2006 + A1:2010); German version EN 61000-6-4:2007 + A1:2011

## 2.2.6 Label

Each device has on the left side an individual series label, which identifies the device.

The serial label includes the following information:

article number  
 article description  
 additional text  
  
 serial number      index      month of delivery  
    year of delivery

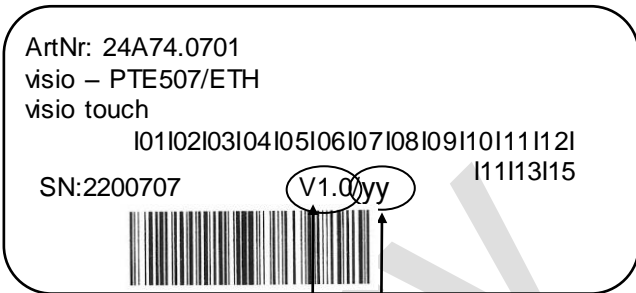

Der Index Vx.x/yy teilt sich hierbei auf in

x.x      Hardware status  
 yy      Software status

Figure 7: Label

<p>WARNING</p> 	<p>Note for devices with the index = „PROTOTYP”.</p> <p>Prototypes are used only for test purposes.</p>
--	---

Currentunit version	Hardware	Software
Prototype: Prototypex/0.yy	Prototype	0.yy
Pilot series V0.x/yy	Pilot series	yy
Series V1.x/yy	Series	yy

## 3 System overview

### eVISIO web



Visualization via  
WEB, VNC or  
Remote technology  
[LINK](#)

### eVISIO control

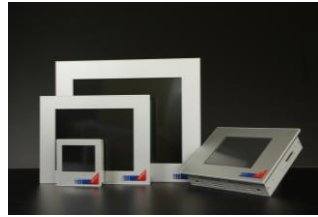

Scalable control panels  
with integrated PLC  
[LINK](#)

### eCOMBO control



Compact PLC systems  
with integrated WEB  
server  
[LINK](#)

### eROBUSTO control



Robust PLC systems with  
high performance  
degree of customization  
[LINK](#)

## 3.1 Communication interfaces



Ethernet

Interface to all peripheral units as stick, keyboard, printer, a.s.o.

With Ethernet can TCP-Modbus as UDP or TCP be used. on the base of socket functions can be added further protocols.

Table 5: Overview communication interfaces



## 4 Device descriptions

### 4.1 Technical data

PREVIEW

eVISIO

Data sheet

PTE715

V0.1 Prototype

**elrest**<sup>®</sup>  
INNOVATION FOR AUTOMATION

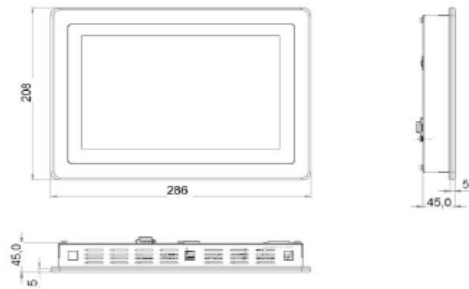

• PCAP Touch • Web browser • Web configuration

Specification	
Graphic display	color TFT LCD 15,6" TFT, 1920 x 1080 pixel, (16:9)
Input	PCAP touch screen (cover glass)
Memory	2MB L2 cache, 2GB DDR3L, 64GB SSD
Processor	Intel® Atom™ E8000 Quad Core 1,04 GHz up to 2 GHz burst
Data buffering	RTC via Goldcap, 35 days buffering time Backup battery (see accessory)
Software	
Operating system	Windows 10 professional english
Interface	
Ethernet	1 x 100/1000BASE-T, RJ45
USB	1 x USB-1.1 and 2.0 Host Typ A; cable length < 3 m
Order-No.:	
24BF1.D001	PTE715H/W10I/L4/P/elrest-AL
Environment/mechanical values	
Supply voltage	24 V DC (18 V...30 V), 15 W...26 W
Power consumption (duration/start-up)	0,65 A / 1,2 A
Housing	Metal housing, glass
IP Rating	Front IP54, Back IP20 acc. EN 60529
Mounting	Front panel mounting
Outside dimension in mm (W x H x D)	410 x 262 x 50
Cut-out dimension in mm (W x H)	394 x 246
Weight approx.	3200 g
Operating temperature	0 °C...45 °C
Storage temperature	-10 °C...70 °C
Relative humidity for operation	10%...85% non-condensing
Relative humidity for storage	5%...85% non-condensing

Standards	
Product standard	EN 61000-6-2:2015 EN 61000-6-4:2011
Accessory	
Mounting material	1 x MB225-3 set of terminal block (6 pieces) x MB225-8 set of terminal block (4 pieces) Number of the terminal blocks per device: 10 pieces
Battery	1 x VARTA CR1/2 AA 3 V Lithium

© 2017 elrest Automationssysteme GmbH. All rights reserved.

The information contained in this document is subject to change without notice and do not constitute any obligation on the part of elrest Automationssysteme GmbH. The software and / or databases described in this document, are provided under a license agreement and a secrecy agreement. The software and / or databases may only be used or copied in accordance with the terms of the agreement. It is unlawful to copy the software to another medium, as far as this is not expressly permitted in the license or secrecy agreement. Without the express written permission of elrest Automationssysteme GmbH neither this manual nor parts thereof may be used for any purpose, in any form by any means, electronically or mechanically, reproduced or transmitted by photocopy or recording.

Illustrations and descriptions as well as dimensions and technical data correspond to the circumstances or intentions at the time of the printing of this brochure. We reserve the right to make changes of any kind, in particular as far as they result from technical progress, economic execution or similar. The external connection of the devices is carried out by the user.

Do you have questions, requests or suggestions?

You can in-depth comprehensive information about elrest on our website: [www.elrest.de](http://www.elrest.de)

Your direct line to elrest: +49 (0) 7021-92025-0

or contact us at: [vertrieb@elrest.de](mailto:vertrieb@elrest.de)



E510013-1-0

elrest Automationssysteme GmbH · Leibnizstraße 10 · D-73230 Kirchheim unter Teck  
Tel: +49 (0) 7021-92025-0 · Fax: +49 (0) 7021-92025-29 · [vertrieb@elrest.de](mailto:vertrieb@elrest.de) · [www.elrest.de](http://www.elrest.de)

Illustrations and descriptions as well as dimensions and technical data correspond to the circumstances or intentions at the time of this brochure. Changes of any kind, in particular as far as they result from technical progress, economic performance or shall remain reserved.



#### 4.1.1 Dependence of the storage temperature to the humidity

There are relationships between the storage temperature and the humidity.

Field:

Example	Relative humidity	Ambient temperature max.	
1	85%	70°C	In conditions of relative humidity of more than 90% can the device be stored at a maximum temperature of 70 °C.
2	60%	60°C	In conditions of storage temperatur of 60 °C a maximum relative humidity of 60% is be allowed.

## 4.2 Rear view of the interfaces

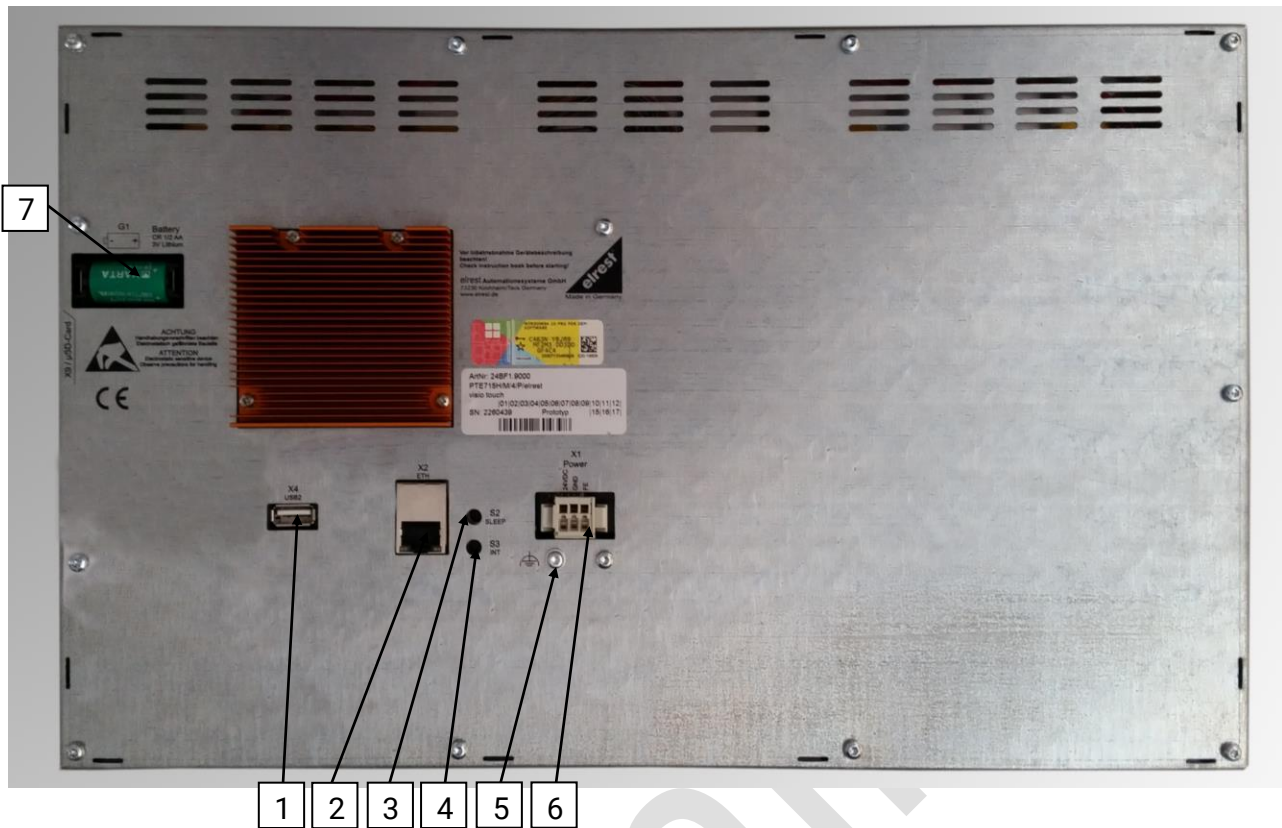

Figure 8: Rear view of the interfaces

No.	Chapter		Indication
1	<a href="#">X4 USB0 2.0 host interface</a>	X4	USB0 ; Type-A
2	<a href="#">X2 Gigabit Ethernet- interface</a>	X2	100/1000 BASE-T, RJ45 with 2 integrated LEDs
3	<a href="#">S2 SLEEP Taster</a>	S2	Sleep- / Reset function
4	<a href="#">S3 INT Taster</a>	S3	Actually no function
5	<a href="#">Functional earth (FE)</a>		Functional earth (FE)
6	<a href="#">X1 Power supply</a>	X1	System-power supply 24 VDC
7	<a href="#">Battery compartment Changing the backup battery</a>		Battery compartment for Varta LithiumCR1/2 AA 3V

Table 1: Legend for the rear view

## 4.3 Terminal assignment

The interfaces for the PTE715 are listed below.

### 4.3.1 X1 : Power supply

With this connector will be the panel supplied with the operating voltage. It is also protected against reverse polarity.

- Only use power supply of the safty class SELV / PELV.
- The system automatically switches off below the minimum voltage (approx. 16V).

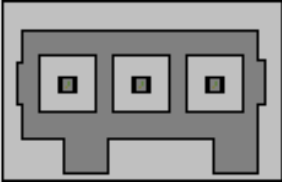
Power supply X1	PIN	Allocation	Function
<div style="text-align: center;">           1    2    3   </div> <p>Figure 9: X1 Power supply</p>	1 2 3	24VDC 0 VDC FE	Power supply (18VDC .... 30VDC) / I <sub>max</sub> 1A GND – Reference potential (ground) Function earth

### 4.3.2 Function earth (FE)

#### Notice



The PTE507 must be integrated into the grounding concept via its function ground (FE) connection. For this purpose, a ground tape (single cable not optimal) should be mounted on the FE screw connection.









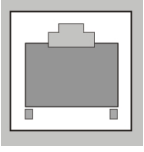

### 4.3.3 X2 Gigabit Ethernet interface

This interface is executed as a RJ45 socket and integrated LEDs.

The transmission rate is 100/1000 Mbit/s Ethernet-MAC / -PHY supports Auto-MDI(X).

The connections and the cables acc. CAT 5e and the guidelines for Ethernet interfaces.

Interface X2	PIN	Allocation	Function	Cable color	
 <p>PIN1</p> <p>Figure 10: X2 Ethernet</p>	1	TX+_D1	Transmit Data +	White/ orange	
	2	TX-_D1	Transmit Data -	Orange	
	3	RX+_D2	Receive Data +	White / green	
	4	BI+_D3	Bi-directional+	Blue	
	5	BI-_D3	Bi-directional-	White / blue	
	6	RX-_D2	Receive Data -	Green	
	7	BI+_D4	Bi-directional+	White / brown	
	8	BI-_D4	Bi-directional-	Brown	

A cross-over cable with appropriate connection must be used for connecting the PTE Ethernet interface without a hub to a further Ethernet interface. It is important that the wire pairs are configured as shown on the left.

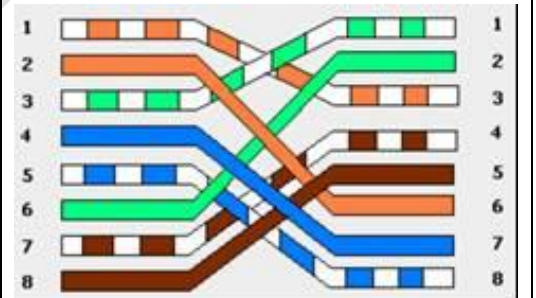

#### 4.3.3.1 Technical data

Gigabit- Ethernet	1 x RJ-45
Transmission medium at 100Base-TX	At least Twisted Pair SF-UTP, 100 Ω, CAT 5e, 100 m max. cable length
Transmission medium at 1000Base-T	At least Twisted Pair SF-UTP, 100 Ω, CAT 5e, 100 m max. cable length
Transmission rate	100/1000 Mbit/s
Protocols	DHCP, DNS, FTP, HTTP, HTTPS, SSH

#### 4.3.4 LEDs for the Ethernet interface

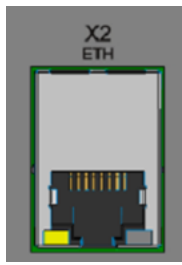

Figure 11: LEDs X2

The Ethernet-interface X2 is equipped with two LEDs for displaying the operating states LINK and ACTIVITY.



	LED	Color	Meaning
	LINK	Green	Connection to the communication device is available
	ACT	Yellow	Communication is available

Figure 12: LEDs X2 color

#### 4.3.5 X4 USB 2.0 Host interface

The interface is executed as a USB 2.0-Host interface with Type A socket.

Power supply can be max. 500 mA for each interface and is protected by overcurrent detection

The connection for this interface acc. the USB-specification, 2.0 High-Speed, max. transmission rate: 480 MBit/s.

The cable length must be <3 m

The following table and illustration shows the pin assignment of this interface.

Interface X4	PIN	Allocation	Function
	1	USB_VCC1	USB + 5 VDC
	2	USB_N	USB Data line D-
	3	USB_P	USB Data line D+
	4	USB_GND	USB GND

Figure 13: X4 USB-interface

#### 4.3.6 S2 key „SLEEP / RESET“

The key S2 operates as follows:

Press > 8 sec:            Triggering RESET on the CPU with Warm-Boot function;

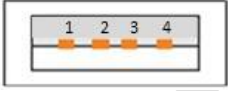
the device will be restarted during the Warm-Boot-phase.

#### 4.3.7 S3 key „INT“

Currently, the key has no function.

#### 4.3.8 Battery compartment

The detailed use is described in the chapter [Changeing buffer battery](#)

Preliminary





## 5 Software

### 5.1 General informationen

Further information can be downloaded from our homepage:

With the link [Kunden Login](#) you can get directly to the download area:

- Enter user name and password 
- Public  
- If nonexistent, please contact our [support](#)..

#### 5.1.1.1 Input

The device can be operated via the following:

- Touch operation
- Virtual keyboard
- Inputs via USB devices, e.g. keyboard and mouse.

#### 5.1.2 RTC (Real time clock)

The product has a clock for internal timer use.

The clock continues to run for at least 35 days after switching off the power supply (at 25°C).

This can be set in system settings or BIOS.

#### 5.1.2.1 Capacitive Touch



Tip and sharp-edged objects can damage the touch screen.

The slightest wear causes the operation with the fingertip.

Avoid touching fingernails to the touch surface during operation.

### 5.1.3 Turn on

The device is connected to the power supply via X1.

*After several seconds, the homescreen appears.*



Figure 14: Homescreen

#### 5.1.4 Login

The user name is displayed and the password can be entered in the white field below.  
The default setting on delivery for the password is: demoipc



Figure 15: Login

### 5.1.5 Desktop

After the Login the desktop will be displayed

The default IP-Settings is DHCP.



Figure 16: Desktop

## 6 Maintenance and servicing

### 6.1 Maintenance

#### 6.1.1 General

- The following must always be observed or checked daily:
- The permissible ambient conditions must be adhered
- Is the housing temperature unusually high?

The visio devices are designed for maintenance-free operation. Maintenance is limited of changing backup battery.

#### 6.1.2 Changing backup battery

In the visio devices are a backup batterie installed. The battery ensures, if the power supply is interrupted, the internal clock continues to run.

The lifetime of the battery is approx. 3 years under normal operating conditions

Please use only a VARTA CR 1/2 AA Lithium, this is a 3V battery with 970mAh.



#### Sources of supply

The battery can be obtained from elrest Automationssysteme GmbH

#### Requirements:

The battery should be replaced within 10 minutes

- The following points must be observed when changing the battery:
  - Release the battery cover.
  - Remove the battery cover.
  - Remove the battery.
  - Insert the new battery, **observing the polarity** (see symbol on the battery base and the label on the housing lid).
  - Time and date must be checked.

	<p>Do not charge, disassemble or burn the battery!</p> <p>The used lithium battery may cause damage from fire or chemical burns if misused. The battery must not be charged, disassembled, warmed or burned to over 100 ° C (212 ° F).</p> <p>Replace battery only by same type!</p> <p>Replace the lithium battery only with a battery of the same type. There is a risk of fire or explosion when using another lithium battery.</p> <p>The battery must only be replaced by qualified personnel. Please observe the ESD / ESD guidelines before changing the battery.</p> <p>Improper handling of the batteries may result in a risk of explosion:</p> <ul style="list-style-type: none"> <li>Never load</li> <li>Do not open</li> <li>Do not short-circuit</li> <li>Do not reverse polarity</li> <li>Do not heat above 100 ° C</li> <li>Protect from direct sunlight</li> <li>Do not allow moisture to condense on batteries</li> </ul> <p>In the case of a necessary transport, the dangerous goods schedule for the relevant carriers (labeling obligation) has to be complied.</p> <p>Used lithium batteries have to be dumped in the hazardous waste. They must be individually packed in a sealed plastic bag for disposal.</p>
	<p>Do not open the lithium battery. <b>Poisoning!</b></p>



General information:

Observe the following safety instructions for proper handling and disposal of lithium batteries

### 6.1.3 *Device temperature*

	<p><b>The ambient temperature</b> of the PTE must not be less than 0 ° C and not higher than 45 ° C during operation.</p> <p>Otherwise, all warranty claims will expire and the device may be destroyed.</p>
---	--

### 6.1.4 Cleaning

Turn off the PTE and all connected devices.

If necessary, the device must be cleaned with a nebulized microfiber cloth.

Do not use corrosive detergents, thinners, abrasive cleaners, or abrasive materials that could result in scratches.

### 6.1.5 Device failure

The PTE was checked before delivery and left the house in perfect condition.

Should an error occur, you can find on our homepage: / ["Service / Return Services"](#) the RMA form. Please fill it out and send it to us. We will attend immediately!

### 6.1.6 Accessory



Designation	Order number	Comment	
Patchkabel RJ45 zu RJ45	commercially	Connection to master devices	
Terminal block PTE715	MB225-3 and MB225-8	6 pieces 4 pieces	 Symbolic illustration
Battery	Varta Lithium CR1/2 AA 3V	This can be obtained via elrest or specialist shop	

Table 2: Accessory

## 7 Troubleshooting

### 7.1 Service and Support

#### Hotline

For additional support and information contact our hotline with the following times:

Mon-Fri: 8.00- 12.00 and 13.00 - 16.30

Phone: +49 (0) 7021 / 92025-33

Besides, you can of course always contact us by mail or fax.

Fax.: +49 (0) 7021 / 92025-29

e-mail: [support@elrest.de](mailto:support@elrest.de)

#### Training und Workshops

We offer education or project-based workshops for the elrest products.

Please contact our sales department for further information.

Phone: +49 (0) 7021/92025-0

Fax: +49 (0) 7021/92025-29

E-mail: [vertrieb@elrest.de](mailto:vertrieb@elrest.de)



## 8 List of figures

Figure 1: Required space.....	16
Figure 2: Symbolic illustration Terminal block for mounting .....	16
Figure 3 : Attaching of the brackets on the mounting plate .....	17
Figure 5: Dimension drawing PTE507 .....	18
Figure 6: Dimension drawing and mounting cutout .....	18
Figure 7: Connection to other elrest master -devices.....	20
Figure 8: Label.....	23
Figure 9: Rear view of the interfaces .....	28
Figure 10: X1 Power supply .....	29
Figure 11: X2 Ethernet .....	30
Figure 12: LEDs X2 .....	31
Figure 13: LEDs X2 color .....	31
Figure 14: X4 USB- interface .....	31
Figure 15: Homescreen.....	34
Figure 16: Login.....	35
Figure 17: Desktop .....	36

## 9 List of tables

Table 1:Symbolics .....	9
Table 2:Safty note .....	10
Table 3:Mounting position .....	15
Table 4: Dimension of the device.....	18
Table 5:Overview communication interfaces .....	24

## 10 History

<i>Date</i>	<i>Name</i>	<i>Chapter</i>	<i>Changing</i>
08.08.2017	Hm	all	Created

Preliminary



2017 elrest Automationssysteme GmbH. All rights reserved.

The information in this document is subject to change without NOTICE and does not represent a commitment on the part of elrest GmbH. The software and/or databases described in this document are made available subject to a License Agreement and a Nondisclosure Agreement. The software and/or databases may only be used or copied strictly in accordance with the terms of the Agreement. Unless explicitly permitted under the terms of the License or Non-Disclosure Agreement, it is illegal to copy the software to another medium. Reproduction or dissemination of this manual in whole or in part for any purpose, in any form and by any means – electronic, mechanical, photocopying or recording – without the express written permission of elrest Automationssysteme GmbH is prohibited. All illustrations, descriptions, dimensions and technical data correspond to the conditions or intentions at the time of printing of this brochure. The company reserves the right to make any changes, particularly where such changes are the result of technical development, more economic design or similar factors. Customers are solely responsible for the external connection of the devices.

Do you have questions, requests or suggestions?

You can get comprehensive information about **elrest** on our website: [www.elrest.de](http://www.elrest.de)

Your direct line to **elrest**: +49 (0) 7021-92025-00r

Contact us at: [vertrieb@elrest.de](mailto:vertrieb@elrest.de)



elrest Automationssysteme GmbH • Leibnizstraße 10 • D-73230 Kirchheim unter Teck  
Tel: +49 (0) 7021-92025-0 • Fax: +49 (0) 7021-92025-29 • [vertrieb@elrest.de](mailto:vertrieb@elrest.de) • [www.elrest.de](http://www.elrest.de)

Illustrations and descriptions as well as dimensions and technical data correspond to the circumstances or intentions at the time of the printing of this prospectus.

We reserve the right to make changes of any kind, in particular as far as they result from technical progress, economic execution or similar

E602043-1.0

**elrest®**